

Stair Lift Features Comparison Chart

Model Number	SL600	SL350AC / SL350DC	SL3500D	SL500HD
Product	Pinnacle™ Indoor Premium Stair Lift	Summit® AC or DC Power Indoor Stair Lift	Summit® Outdoor Stair Lift	Summit® Heavy Duty Stair Lift
				
Lifting Capacity	350 Lbs	350 Lbs	350 Lbs	500 Lbs
Drive	Patented Worm Drive	Cable Drive	Cable Drive	Cable Drive
Power Source	24 VDC	115 VAC / 24 VDC	115 VAC	115 VAC
Folded Width	11"	14"	14"	29"
Seat Size	19" W x 16" D x 18" H	19" W x 14" D x 14" H	19" W x 14" D x 14" H	23" W x 18.5" D x 16" H
Track Length	16' Standard; Maximum 75'	Maximum 25' *	Maximum 25' *	Maximum 20'
Warranty	Components /Drive Train - 3 Year Rack - Lifetime Batteries - 1 Year	Components - 3 Year Drivetrain - 5 Year Batteries - 1 Year	Components - 3 Year Drivetrain - 5 Year	2 Year
Made in America	Yes	Yes	Yes	Yes
Range of Inclination	27° - 52°	30° - 45°	30° - 45°	30° - 45°

*If track length is greater than 20', maximum lift capacity is reduced to 250 lbs.



STAIR LIFT SYSTEMS

Ascend & Descend Stairs Reliably with Comfort and Ease

Stair Lift Technical Diagrams

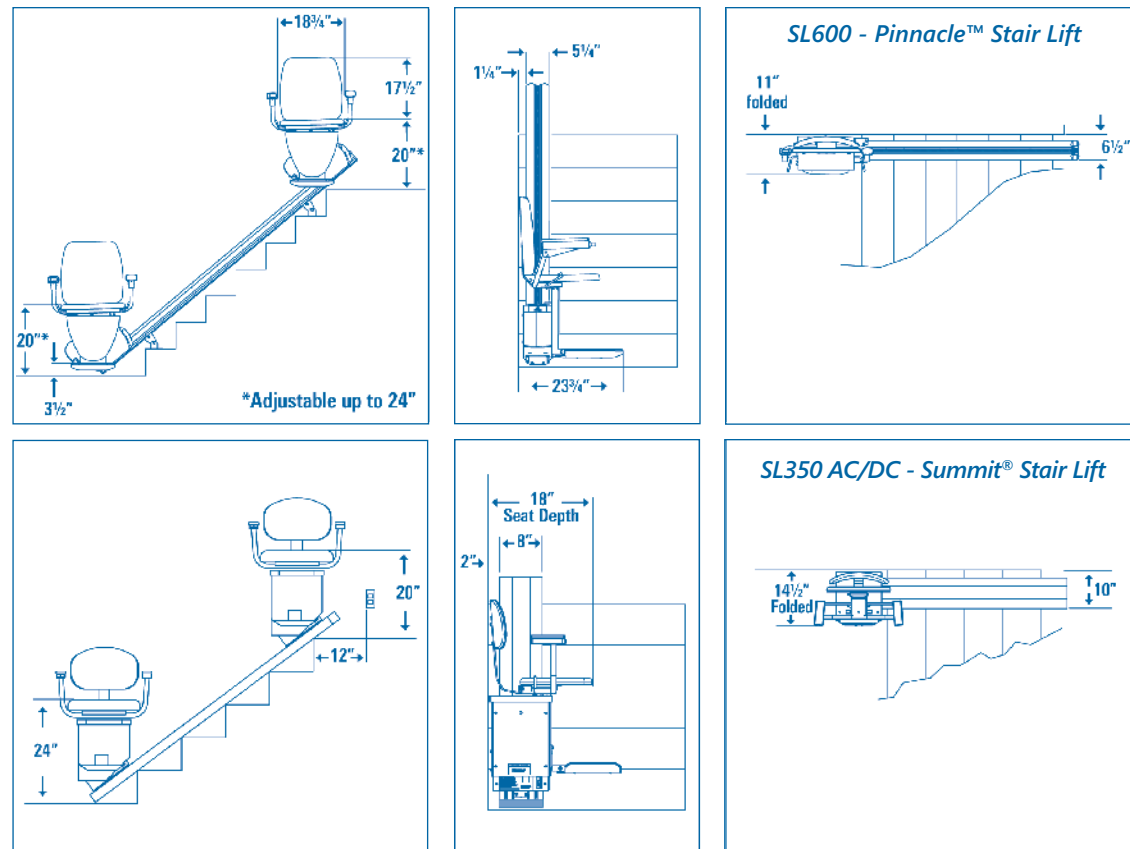

SL600 Pinnacle™ Premium Stair Lift



Peace of Mind Comes in Many Forms.

It's knowing you can get up and down stairs on your own. It's regaining your independence. It's feeling secure each and every time you ride your stair lift—knowing you don't have to worry about power outages, or about parking it precisely at a specific spot on the track. It's knowing you've made the best decision and acquired the right stair lift for you. It's the feeling you get when you own a Pinnacle™ stair lift from Harmar.

This energy efficient stair lift is constructed with the "Harmar Difference"—it is simple to operate, durable and lightweight. Surprisingly compact when folded, the Pinnacle™ boasts a unique patented drive system, wireless remotes and intuitive operating controls with indicator lights.



11" wide when folded

Track Width: 6 1/2"



Above: Wireless remotes for effortless stair lift accessibility



Above and below: Safety sensors on carriage and footrest stop the lift instantly if an obstacle is encountered

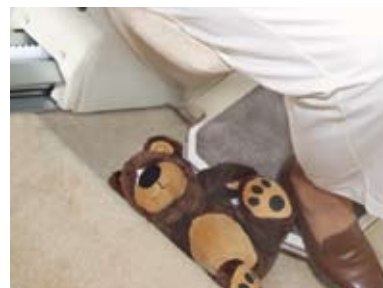

Information At A Glance

Easy operating controls & indicator lights

Responsive Controls

A rocker control with constant-pressure feature stops the lift the instant the control is released

Safety & Security

Removable key lock for safety when you are away (Optional upgrade)

Unique Drive System

This patented drive system requires less energy than a 25 watt lightbulb and can make more than 2 times the amount of trips on battery power than other leading units



Seat upholstery color options: Alpine, light almond, ruby or bluebell (Almond is standard—other colors are optional upgrade)

NO messy greases or lubricants necessary!

SL350AC/DC Summit® Stair Lift

Comfort and Convenience

The backrest has three adjustment settings, and the fold-up footrest adjusts to two different heights for customized comfort. The seat swivels 90° towards the landing at both top and bottom. Spacious and wide, the seat features thick padding and attractive upholstery. The control switch requires little manual dexterity to operate and is located at the end of the armrest.

Safety

The need for secure support is paramount. It's why we use aircraft cable rated up to 4,200 lbs on a drive system that has withstood the test of time for more than 50 years. It's why safety sensors do not allow the lift to run unless the seat is in the proper position. It's why our footrest also has safety sensors to stop the lift if any obstacles are encountered.

Power Options

Summit® stair lifts are available in two convenient power options. Choose between safe, AC electrical operation (low voltage, 24V controls), or add protection against power outages by using our DC battery operated system.



14" wide when folded

Track Width: 10"



Above: Optional side-car basket for carrying groceries, laundry and other items up and down stairs



Above: Wall-mounted call/send controls enable travel to or from either landing at any time

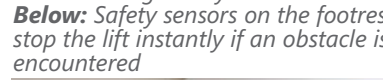

Below: Safety sensors on the footrest stop the lift instantly if an obstacle is encountered



- Rocker controls with constant-pressure functionality stop the lift immediately if the control is released
- Smooth starts and stops
- Mounts to the stairs (not the wall) on either side of staircase

- Wide, comfortable seat rotates 90° at either landing
- Seat & footrest fold to save space
- Separate controls at top & bottom of stairs

Also available from the Summit® Stair Lift Series:

SL3500D Outdoor Model
A unique variant of the SL350, designed to withstand long term outside use

- Header cover, internal chassis cover and a large weatherproof cover included

SL500HD Heavy Duty Model
Quality construction makes this high capacity lift a durable and reliable choice

- Heaviest capacity in the industry! (500 lbs)
- 23" wide, high-backed contoured seat
- Heavy duty armrests & footrests



Seat upholstery color options: Light almond, mocha or evergreen

